

ITEM	PART #	DESCRIPTION	QTY.
1	20-1064B(R)	Wear Strip, Right	1
2	99020	1/4-20 Serrated Flanged Nut	1
3	99158	1/4"-20 x .75" Carriage Bolt	1
4	99159	1/4"-20 x 1.5" Carriage Bolt	1

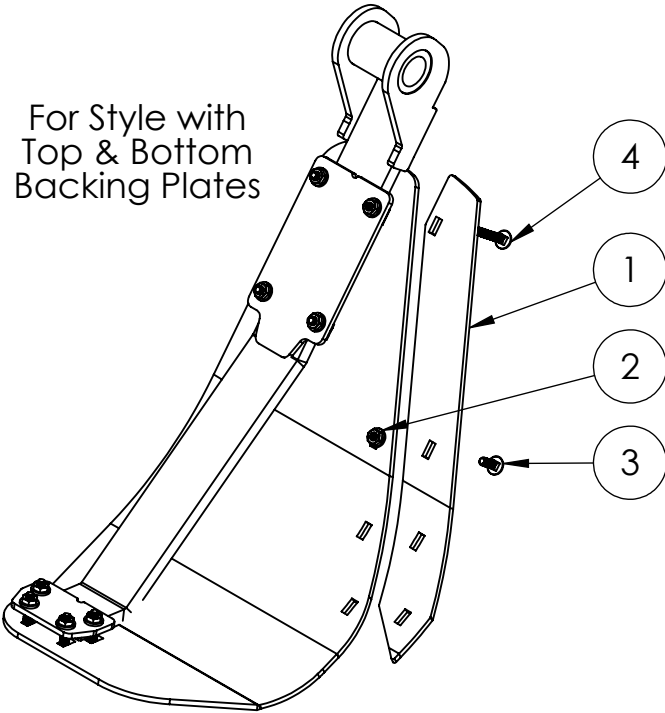

Right Hand Assembly Shown

ITEM	PART #	DESCRIPTION	QTY.
1	20-1064B(R)	Wear Strip, Right	1
2	20-1100B	Wear Strip Tab	1
3	99020	1/4-20 Flanged Nut	2
4	99157	3/8"-16 x 1.5" Carriage Bolt	1
5	99158	1/4"-20 x .75" Carriage Bolt	1
6	99159	1/4"-20 x 1.5" Carriage Bolt	1

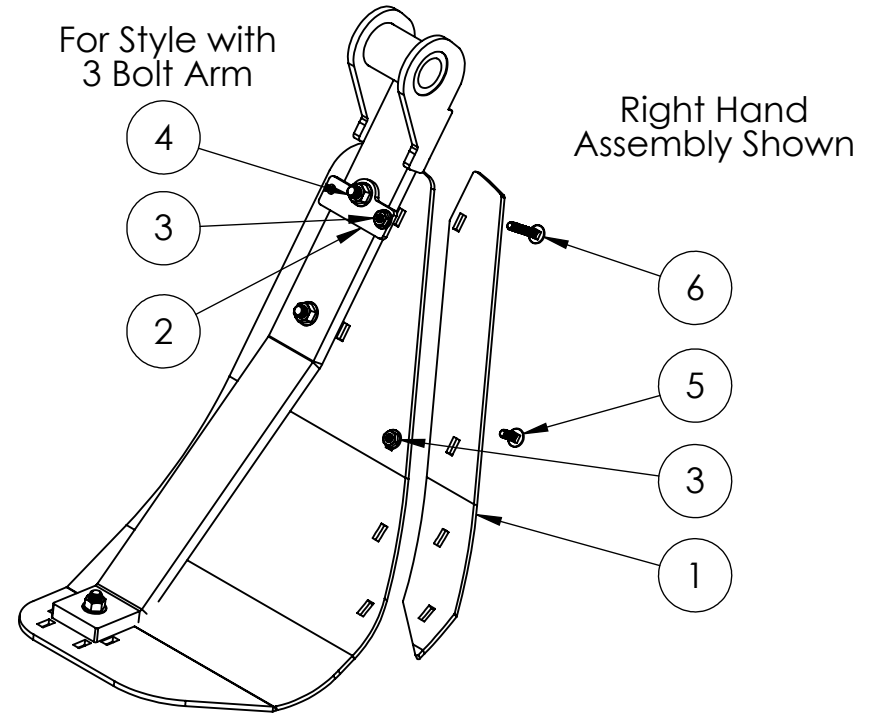

PROPRIETARY AND CONFIDENTIAL

THE INFORMATION CONTAINED IN THIS DRAWING IS THE SOLE PROPERTY OF NOT DEAD YET MANUFACTURING, INC. ANY REPRODUCTION IN PART OR AS A WHOLE WITHOUT THE WRITTEN PERMISSION OF NOT DEAD YET MANUFACTURING, INC. IS PROHIBITED.

COMMENTS:

Shoe Shown is 20AS-AR551 (R)

Complete Kit - \$15.00

TITLE: **Right Hand Stomper Wear Strip**

SIZE **A** DWG. NO. **WS-1064KR** REV

SCALE: 1:6 WEIGHT: SHEET 1 OF 1